

Multilin™ C60

BREAKER PROTECTION SYSTEM

Breaker Monitoring and Control for Substation and Industrial Automation



KEY BENEFITS

- Complete breaker control, protection, monitoring and integration in a single platform
- Advanced automation capabilities for providing customized protection and control solutions
- Modular hardware architecture allows for flexibility in device configurations to cover most breaker applications
- Three independent fiber or copper Ethernet ports for simultaneous/dedicated network connections with advanced 1 microsecond time synchronization via LAN with IEEE® 1588 support
- Reduced wiring through the use of high-speed peer-to-peer communication for accepting trip and close commands from other relays
- Embedded IEC® 61850 protocol with no external communications hardware required
- Phasor Measurement Unit (synchrophasor) according to IEEE C37.118 (2011) and IEC 61850-90-5 support
- Simplified system integration with communications supporting serial, Ethernet and multiple protocols
- Increase network availability by reducing failover time to zero through IEC 62439-3 "PRP" support
- CyberSentry™ provides high-end cyber security aligned to industry standards and services (NERC® CIP, AAA, Radius, RBAC, Syslog)
- Robust network security enabling Critical Infrastructure Protection through user command logging, and dual permission access control
- Advanced fault and disturbance recording, including internal relay operating signals thus eliminating the need for external recording devices
- Complete IEC 61850 Process Bus solution provides resource optimization and minimizes total P&C life cycle costs

APPLICATIONS

- Stand-alone breaker monitoring and control
- Multiple breaker configuration control including breaker-and-a-half and ring bus
- Automatic bus transfer scheme using a single device
- As part of a distributed bay controller

FEATURES

Protection and Control

- Breaker failure
- Synchronism check
- Autoreclose and open pole detector
- Phase, neutral and auxiliary overvoltage
- Neutral and auxiliary overvoltage
- Thermal overload, phase, ground and neutral overcurrent
- Sensitive directional power
- Dual breaker control

Communication

- Networking interfaces: up to three Ethernet ports 100Mb fiber or copper, RS485, RS232, RS422, G.703, C37.94
- Multiple protocols: IEC 61850, DNP 3.0 and Modbus® serial/TCP, IEEE 1588, IEC 60870-5-104 and 103, PRP, SNTP, HTTP, TFTP, EGD
- Direct I/O: secure, high-speed exchange of data between URs for direct transfer trip and I/O extension applications
- Embedded managed Ethernet switch with four 100 Mbit fiber optic ports and 2 copper ports

IEC 61850 Process Bus Interface

- Robust communications with up to 8 HardFiber Bricks
- Redundant architecture for dependability and security

Monitoring and Metering

- Metering: current, voltage, power, energy, frequency
- P & M Class synchrophasors of voltage, current and sequence components: reporting rate 1 to 120 frames/sec
- Advanced recording capabilities deliver a 1024 event recorder, configurable and extended waveform capture and data logger
- Fault Locator
- Setting for security audit trails for tracking changes to the C60 configuration

EnerVista™ Software

- Graphical Logic Designer and Logic Monitor to simplify designing and testing procedures via EnerVista UR Engineer
- Service and update notification toolset ensures device documents and software are up-to-date via EnerVista Launchpad
- EnerVista Integrator providing easy integration of data in the C60 into new or existing monitoring and control systems



imagination at work

Protection and Control

The C60 breaker protection system is a substation hardened controller that provides a complete integrated package for the protection, control, and monitoring of circuit breakers. The C60 supports dual-breaker busbar configurations such as breaker-and-a-half or ring bus arrangements. Signals from up to 4 sets of CT's can be brought into the C60 for internal summation, which is advantageous by still having the individual currents available for metering and the additional protection elements that operate on individual currents.

The C60 provides fast and deterministic execution of programmable logic and extensive I/O options that are necessary for substation automation applications. All of the necessary control logic functions are available for creating automated breaker control schemes, such as the popular maintie-main scheme using a single C60 device.

Using high-speed peer-to-peer communications for inter-device messaging, the C60 can also accept breaker opening, closing and lock-out commands from other devices at a fraction of the cost of hardwiring these signals. As part of the UR Family, the C60 provides superior protection and control including:

C60 - Protection, Metering, Monitoring and Control

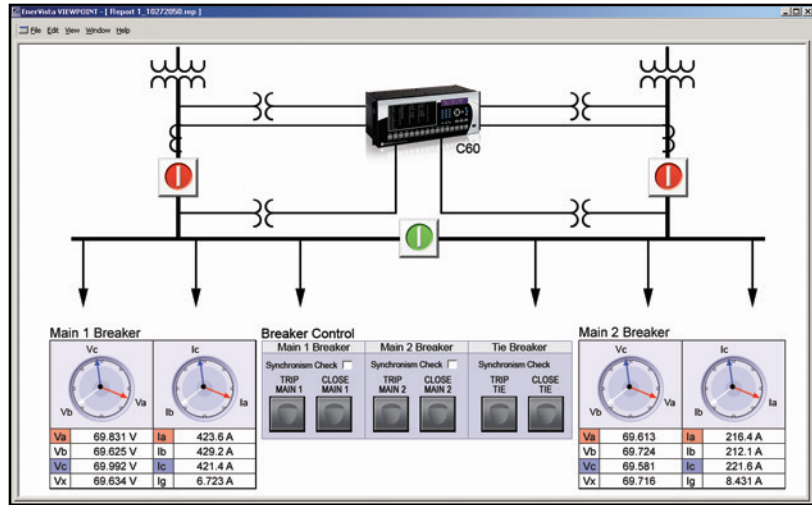

The C60 is the single point for protection, control, metering, and monitoring in one integrated device that can easily be connected directly into DCS or SCADA monitoring and control systems like Viewpoint Monitoring as shown.

Breaker Failure

The breaker failure functions included in the C60 are available to detect breaker failure conditions for both single and three-pole tripping schemes. The C60 provides two independent breaker failure functions, and all of the current source inputs, digital inputs and digital outputs need to perform breaker failure functions on dual breaker schemes, such as breaker-and-a-half or ring bus arrangements. Breaker failure initiation and transfer tripping signals can be done

using hardwired contacts or through communications (IEC 61850 and direct I/O).

Autorecloser

The C60 provides multi-shot autoreclosing on all types of faults for single or three-pole applications with independent dead time for each shot. The protection settings can be changed between shots (typical application being an accelerated zone 1 extension scheme). Autoreclosure can also be dynamically blocked by user-programmable

Functional Block Diagram

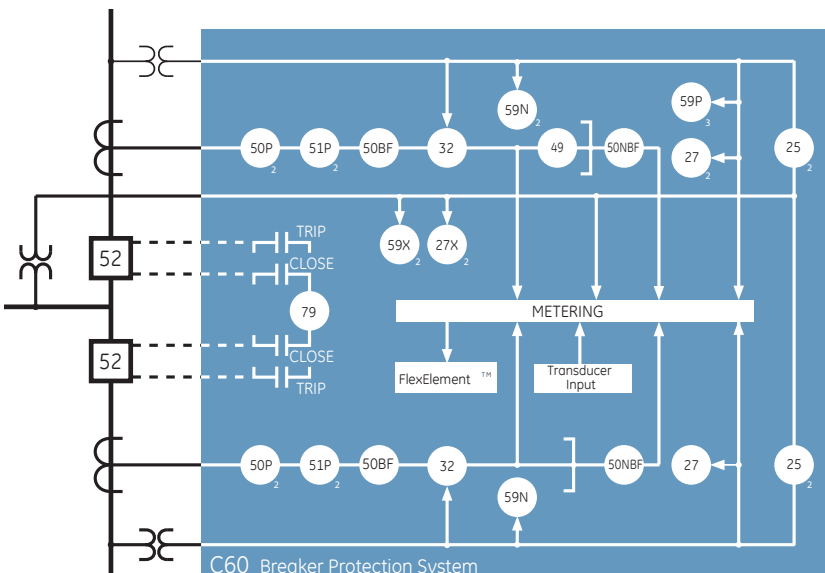

ANSI Device Numbers & Functions

Device Number	Function
25(4)	Synchrocheck
27P	Phase Undervoltage
27X	Auxiliary Undervoltage
32	Directional Power
49	Thermal Overload
50G	Ground Instantaneous Overcurrent
50N	Neutral Instantaneous Overcurrent
50P	Phase Instantaneous Overcurrent
51G	Ground Time Overcurrent
51N	Neutral Time Overcurrent
51P	Phase Time Overcurrent
59N	Neutral Overvoltage
59P	Phase Overvoltage
59X	Auxiliary Overvoltage
79	Autoreclose
50BF	Breaker Failure
50NBF	Neutral Instantaneous Breaker Failure

logic. Four different autoreclose modes are available, enabling users to select the reclosure mode to suit specific applications. The autoreclose modes can be dynamically changed by any internal FlexLogic™ digital operand, allowing flexibility with changing system conditions.

Synchrocheck

The C60 provides four synchrocheck elements that monitor voltage difference, phase angle difference and slip frequency to ensure proper breaker closure as per user requirements. Any of the four synchrocheck elements can be dynamically blocked or unblocked by other elements or user logic, allowing coordination with other C60 protection settings and groups. The C60 provides additional enhancements in synchronizing by checking dead source conditions for synchronism bypass under these conditions.

Overcurrent and Thermal Elements

Overcurrent protection is delivered through instantaneous and time overcurrent elements available for phase, neutral, ground and sensitive ground protection. Most of the standard protection curves are provided. Thermal overload elements as per the IEC 255-8 standard are also available.

Sensitive Directional Power

Two separate directional power elements are provided to detect reverse and low forward power conditions for use in IEEE 1547 DG interconnection anti-islanding protection.

Breaker Control

The C60 allows for control of up to two breakers through commands given to it from either local or remote users. The C60 front panel can have 16 user-configurable pushbuttons that can be used to select and operate the breaker functions. Each button can be customized and labeled for easy operator identification. The C60 can also accept breaker operation commands from remote users through one of the many available communication protocols including Modbus, DNP 3.0, IEC 61850, and IEC 60870-5-104.

IEC 61850 Process Bus

The IEC 61850 Process Bus module is designed to interface with the GE Multilin

FlexLogic Designer

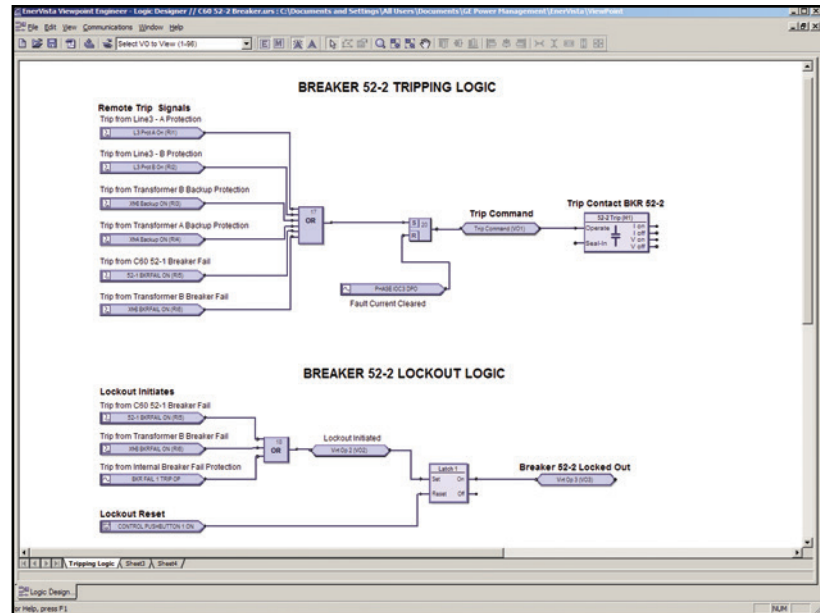

FlexLogic allows for the creation of customized C60 breaker control schemes, including the receipt of trip and close commands from other devices, and the creation of logic to replace the need for external lockout relays.

HardFiber System, allowing bi-directional IEC 61850 fiber optic communications. The HardFiber System is designed to integrate seamlessly with existing Universal Relay (UR) applications, including protection functions, FlexLogic, metering and communications.

The GE Multilin HardFiber System offers the following benefits:

- Communicates using open standard IEC 61850 messaging
- Drastically reduces P&C design, installation and testing labor by eliminating individual copper terminations
- Integrates with existing C60's by replacing traditional CT/VT inputs with the IEC 61850 Process Bus module
- Does not introduce new cyber security concerns

Visit the HardFiber System product page on the GE Multilin web site for more details.

Advanced Automation

The C60 incorporates advanced automation features including powerful FlexLogic programmable logic, communication, and SCADA capabilities that far surpass what is found in the average breaker relay or

controller. The C60 integrates seamlessly with other UR relays for complete breaker management including reclosing, load shedding, and synchronism applications.

FlexLogic

FlexLogic is the powerful UR-platform programming logic engine that provides the ability to create customized protection and control schemes, minimizing the need and associated costs of auxiliary components and wiring. Using FlexLogic, the C60 can be programmed to provide the required logic for performing complete breaker control in schemes that may include simple single breaker management, equipment backup protection as well as sophisticated automatic transfer schemes.

Scalable Hardware

The C60 is available with a multitude of I/O configurations to suit the most demanding application needs. The expandable modular design allows for easy configuration and future upgrades.

- Multiple CT/VT configurations allow for the implementation of many different schemes, including single and dual breaker applications
- Flexible, modular I/O covering a broad range of input signals and tripping schemes

- RTDs and DCmA inputs are available to monitor equipment parameters such as temperature and pressure

Monitoring and Metering

The C60 includes high accuracy metering and recording for all AC signals. Voltage, current, and power metering are built into the relay as a standard feature. Current and voltage parameters are available as total RMS magnitude, and as fundamental frequency magnitude and angle.

Fault and Disturbance Recording

The advanced disturbance and event recording features within the C60 can significantly reduce the time needed for postmortem analysis of power system events and the creation of regulatory reports. Recording functions include:

- Sequence of Event (SOE)
 - 1024 time stamped events
- Oscillography
 - 64 digital & up to 40 analog channels
 - Events up to 45s in length
- Data Logger and Disturbance Recording
 - 16 channels up to 1 sample/cycle/channel

- Fault Reports
 - Powerful summary report of pre-fault and fault values

The very high sampling rate and large amounts of storage space available for data recording in the C60 can eliminate the need for installing costly stand-alone recording equipment.

Advanced Device Health Diagnostics

The C60 performs comprehensive device health diagnostic tests at startup and continuously during run-time to test its own major functions and critical hardware. These diagnostic tests monitor for conditions that could impact security and availability of protection, and present device status via SCADA communications and front panel display. Providing continuous monitoring and early detection of possible issues help improve system uptime.

- Comprehensive device health diagnostic performed at startup
- Monitors the CT/VT input circuitry to validate the integrity of all signals

Cyber Security – CyberSentry UR

CyberSentry UR enabled UR devices deliver full cyber security features that help customers to comply with NERC CIP and NIST® IR 7628 cyber security requirements. This software option delivers the following core features:

AAA Server Support (Radius/LDAP)

Enables integration with centrally managed authentication and accounting of all user activities and uses modern industry best practices and standards that meet and exceed NERC CIP requirements for authentication and password management.

Role Based Access Control (RBAC)

Efficiently administrate users and roles within UR devices. The new and advanced access functions allow users to configure up to five roles for up to eight configurable users with independent passwords. The standard “Remote Authentication Dial In User Service” (Radius) is used for authentication.

Event Recorder (Syslog for SEM)

Capture all cyber security related events within a SOE element (login, logout, invalid password attempts, remote/local access,

Specialized Protection & Control

Power System Troubleshooting

The C60 contains tools that allow for the early detection of impending breaker problems and allow for maintenance to be performed before serious damage occurs.

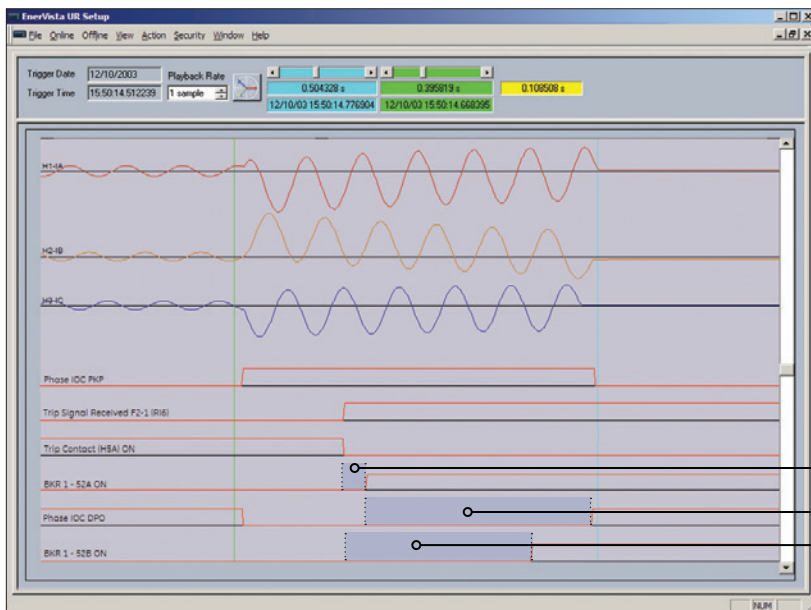

Triggering a waveform on each breaker operation can identify changes in the length of time each part or mechanism in the breaker takes to perform its function.

- **Breaker Latch Release Time:**
Indicates how long it took for the breaker latch to release from the time the trip coil was energized by the relay.
- **Arc Extinguish Time:**
Indicates the length of time that was required for the breaker to extinguish the arc and finally clear the fault.
- **Breaker Mechanism Travel Time:**
Indicates time interval required for the breaker mechanism to travel to its rest position.

user in session, settings change, FW update, etc), and then serve and classify data by security level using standard Syslog data format. This will enable integration with established SEM (Security Event Management) systems.

Communications

The C60 provides advanced communications technologies for remote data and engineering access, making it easy and flexible to use and integrate into new and existing infrastructures. Direct support for fiber optic Ethernet provides high-bandwidth communications allowing for low-latency controls and high-speed file transfers of relay fault and event record information. The available three independent Ethernet ports, redundant Ethernet option and the embedded managed Ethernet switch provide the means to create fault tolerant communication architectures in an easy, cost-effective manner without the need for intermediary communication hardware.

The C60 supports the most popular industry standard protocols enabling easy, direct integration into DCS and SCADA systems.

- IEC 61850 with 61850-90-5 support
- DNP 3.0
- Ethernet Global Data (EGD)
- IEC 60870-5-103 and IEC 60870-5-104
- Modbus RTU, Modbus TCP/IP
- PRP as per IEC 62439-3
- IEEE 1588 for time synchronization

Interoperability with Embedded IEC 61850

Use the C60 with integrated IEC 61850 to lower costs associated with breaker protection, control and automation. GE Digital Energy's leadership in IEC 61850 comes from thousands of installed devices and follows on extensive development experience with UCA 2.0.

- Replace expensive copper wiring between devices with direct transfer of data using GOOSE messaging
- Configure GE systems based on IEC 61850 and also monitor and troubleshoot them in real-time with EnerVista Viewpoint Engineer
- Multicast IEEE C37.118 synchrophasor data between PMU and PDC devices using IEC 61850-90-5

Direct I/O Messaging

Direct I/O allows for the sharing of high-speed digital information between multiple UR relays via direct back-to-back connections or multiplexed through a standard DS0 multiplexer channel bank. Regardless of the connection method, direct I/O provides continuous real-time channel monitoring that supplies diagnostics information on channel health.

Direct I/O provides superior relay-to-relay communications that can be used in advanced interlocking, generation rejection and other special protection schemes.

- Communication with up to 16 UR relays in single or redundant rings rather than strictly limited to simplistic point-to-point configurations between two devices
- Connect to standard DS0 channel banks through standard RS422, G.703 or IEEE C37.94 interfaces or via direct fiber optic connections
- No external or handheld tester required to provide channel diagnostic information

Simplifying Fault and Disturbance Analysis

CreatedTime	CreatedTime	SourceName	Source Type	Event
12/19/2006	16:31.230643	C60 52-2 Breaker	UR	L2 ProtA Trip OFF (R16)
12/19/2006	16:31.234791	D60_Line_2	UR	Send Trip OFF (RO11)
12/19/2006	16:31.234791	D60_Line_2	UR	Protection Trip OFF (VO6)
12/19/2006	16:31.234791	D60_Line_2	UR	Phase Dist Z1 OFF
12/19/2006	16:31.233645	C60 52-2 Breaker	UR	Phase IOC3 OFF
12/19/2006	16:31.227139	C60 52-2 Breaker	UR	52-2 52B ON
12/19/2006	16:31.288617	C60 52-2 Breaker	UR	52-2 52A OFF
12/19/2006	16:31.269485	C60 52-2 Breaker	UR	Oscillography Triggered
12/19/2006	16:31.269485	C60 52-2 Breaker	UR	Trip 52-2 ON (CO1)
12/19/2006	16:31.269485	C60 52-2 Breaker	UR	Trip Command ON (VO2)
12/19/2006	16:31.269485	C60 52-2 Breaker	UR	L2 ProtA Trip ON (R16)
12/19/2006	16:31.265874	D60_Line_2	UR	Trip Signal ON (RO11)
12/19/2006	16:31.265874	D60_Line_2	UR	Oscillography Triggered
12/19/2006	16:31.265874	D60_Line_2	UR	Protection Trip ON (VO6)
12/19/2006	16:31.265874	D60_Line_2	UR	Phase Dist Z1 OP

The events recorded in multiple GE devices can be collected and merged into a single station-wide SOE record to simplify the tracking of substation operations.

LAN Redundancy

Substation LAN redundancy has been traditionally accomplished by reconfiguring the active network topology in case of failure. Regardless of the type of LAN architecture (tree, mesh, etc), reconfiguring the active LAN requires time to switchover, during which the LAN is unavailable. UR devices deliver redundancy as specified by PRP-IEC 62439-3, which eliminates the dependency on LAN reconfiguration and the associated switchover time. The UR becomes a dual attached node that transmits data packets over both main and redundant networks simultaneously, so in case of failure, one of the data packets will reach the receiving device with no time delay.

Multi-Language

UR devices support multiple languages: English, French, Russian, Chinese, Turkish and German. These language options are available on the front panel, in the EnerVista setup software, and in the product manuals. Easily switch between English and an additional language on the local displays without uploading new firmware.

EnerVista Software

The EnerVista suite is an industry-leading set of software programs that simplifies every aspect of using the C60 relay. The EnerVista suite provides all the tools to monitor the status of the protected asset, maintain the relay, and integrate information measured by the C60 into DCS or SCADA monitoring systems. Convenient COMTRADE and SOE viewers are an integral part of the UR setup software included with every UR relay, to carry out postmortem event analysis to ensure proper protection system operation.

EnerVista Launchpad

EnerVista Launchpad is a powerful software package that provides users with all of the setup and support tools needed for configuring and maintaining GE Multilin products. The setup software within Launchpad allows for the configuration of devices in real-time by communicating using serial, Ethernet, or modem connections, or offline by creating setting files to be sent to devices at a later time.

Included in Launchpad is a document archiving and management system that ensures critical documentation is up-to-date and available when needed. Documents made available include:

- Manuals
- Application Notes
- Guideform Specifications
- Brochures
- Wiring Diagrams
- FAQ's
- Service Bulletins

Viewpoint Monitoring

Viewpoint Monitoring is a simple-to-use and full-featured monitoring and data recording software package for small systems. Viewpoint Monitoring provides a complete HMI package with the following functionality:

- Plug-&-Play Device Monitoring
- System Single-Line Monitoring & Control
- Annunciator Alarm Screens
- Trending Reports
- Automatic Event Retrieval
- Automatic Waveform Retrieval

Viewpoint UR Engineer

Viewpoint UR Engineer is a set of powerful tools that allows the configuration and testing of GE relays at a system level in an easy-to-use graphical drag-and-drop environment. Viewpoint UR Engineer provides the following configuration and commissioning utilities:

- Graphical Logic Designer
- Graphical System Designer
- Graphical Logic Monitor
- Graphical System Monitor

Viewpoint Maintenance

Viewpoint Maintenance provides tools that will create reports on the operating status of the relay, simplify the steps to download fault and event data, and reduce the work required for cyber security compliance audits. Tools available in Viewpoint Maintenance include:

- Settings Security Audit Report
- Device Health Report
- Single-Click Fault Data Retrieval

EnerVista Integrator

EnerVista Integrator is a toolkit that allows seamless integration of GE Multilin devices into new or existing automation systems. Included in EnerVista Integrator is:

- OPC/DDE Server
- GE Multilin Drivers
- Automatic Event Retrieval
- Automatic Waveform Retrieval

User Interface

The C60 front panel provides extensive local HMI capabilities. The local display is used for monitoring, status messaging, fault diagnosis, and device configuration. User-configurable messages that combine text with live data can be displayed when user-defined conditions are met.

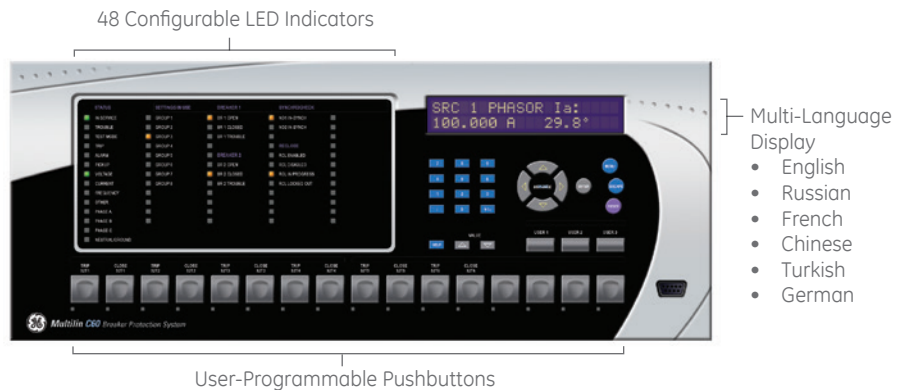

Typical Wiring

TYPICAL CONFIGURATION
THE AC SIGNAL PATH IS CONFIGURABLE

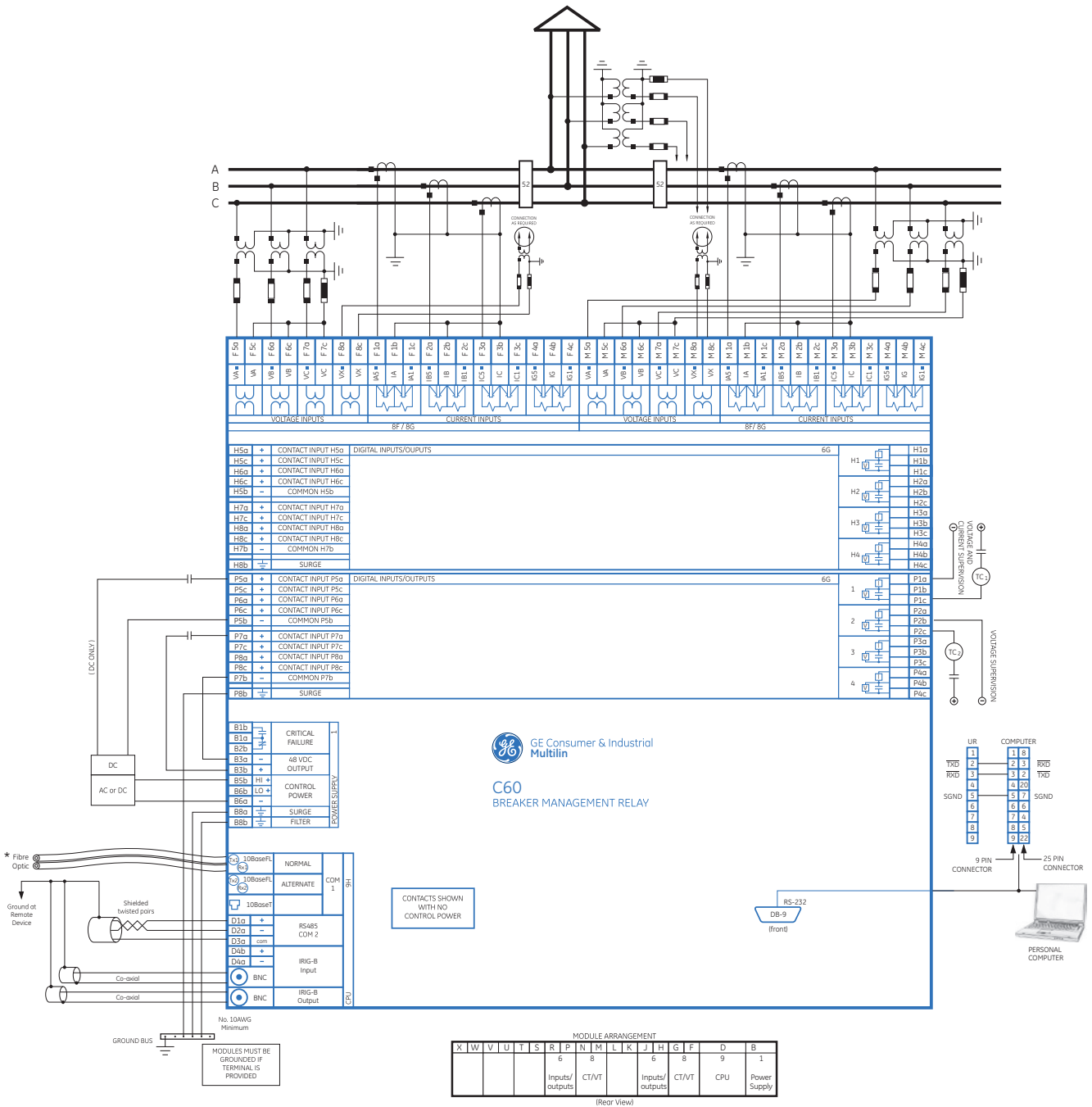

This diagram is based on the following order code: C60-H00-HCL-F8F-H6G-M8F-P6G
This diagram provides an example of how the device is wired, not specifically how to wire the device. Please refer to the Instruction Manual for additional details on wiring based on various configurations.

Specialized Protection & Control

